

AN INTRODUCTION TO HYDRONIC UNDERFLOOR HEATING

a concise guide for architects & specifiers
on planning underfloor heating systems



Contents

Underfloor heating: the ultimate in comfort & design	3
Underfloor Heating Methods	5
Can underfloor heating be used with radiators on the same system?	6
Choices of Heat Sources	7
What are the running costs like for an underfloor heating system?	8
What level of control is there in a hydronic underfloor heating system?	9
Design & installation issues to consider when planning underfloor heating	10
Design & installation process for in-slab & Screed underfloor heating systems	16
Our Expertise	17

Underfloor heating: the ultimate in comfort & design

Luxurious, silent & discrete

Underfloor heating is the most luxurious form of heating as radiant heat is evenly distributed throughout the room; wall to wall; floor to ceiling.

Hard floor surfaces are warm to the touch – this is very important with increased numbers of new houses being built with concrete floor surfaces

And the system is totally hidden from view and takes up no wall space – very important to many people, especially where large glazed areas mean there is little or no wall space.

With no air being blown around it is totally silent.



The heat can be provided by specially designed air to water heat pumps, or by boilers fuelled by gas, diesel or wood.

The floor can be heated either by electric elements under the floor covering, or by hot or warm water being pumped through pipes inside the floor, also known as hydronic heating . This guide is only concerned with hot water pipe, hydronic, underfloor heating systems.

Energy efficient

Underfloor systems can run at much lower temperatures than radiator systems which increases the efficiency of the boilers and heat pumps used to supply the heat.

How does underfloor heating work?

The heat source: A boiler or heat pump supplies heat to the system by heating the water that is pumped through it.

Primary pipework carries the heat from the heat source to the manifold(s).

Manifolds distribute the heat to the underfloor pipe loops.

Pipe loops, with hot water flowing through them, heat the floor, typically at least 1 loop for every 20m² of heated floor area.

Controller switches the heat source on and off, and directs the heat to where it is needed to heat the rooms to the desired temperature.

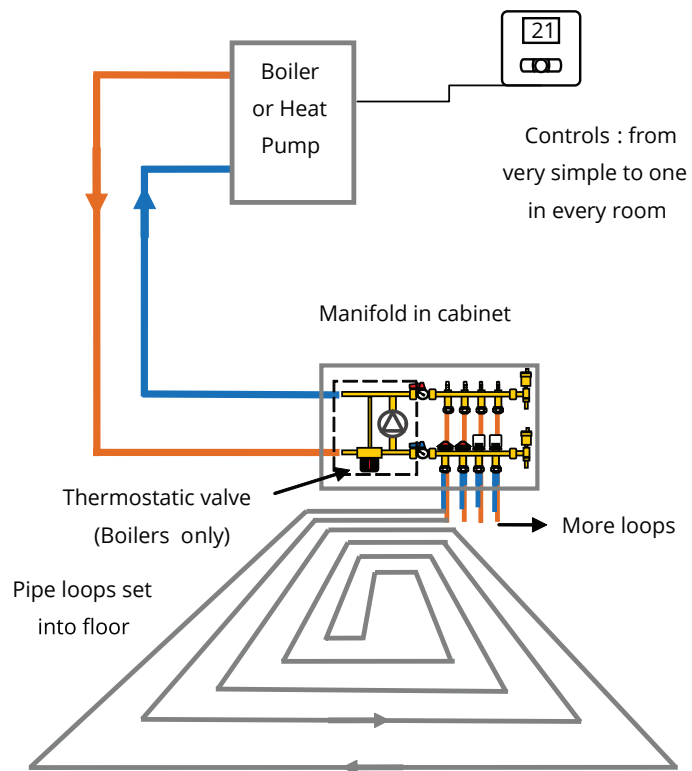

Can underfloor heating be installed in my home?

Heating Method	New Build?	Retro-fit to existing home?
In-slab (Kiwi UF)	✓	✗
European screed	✓	✓
Multitubo Micro-screed	✓	✓
Alloy plate system for timber joist floors	✓	✓

When underfloor is retrofitted the floor level will be raised which means door heights etc will be reduced, unless spreader plates are used under a timber floor.

Underfloor Heating Methods

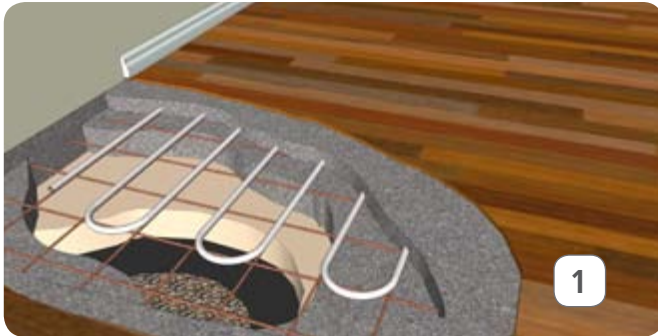

1. In-slab, 'Kiwi', underfloor heating

The most commonly used form of central heating in New Zealand.

Pipes are laid on polystyrene insulation or attached to reinforcing mesh. Concrete is poured over the mesh and insulation. These concrete slabs are usually between 100-150mm in thickness.

Advantages: Relatively inexpensive and simple to install. Large thermal mass retains heat.

Disadvantages: Whilst thicker slabs mean greater thermal mass, they also mean they are not as quick to heat should they lose temperature.

3. Multitubo micro-screed

A much thinner system using smaller pipes laid into a special moulded floor plate.

A screed (thin layer of concrete) is spread over the pipes, with the flooring then laid on top of this. Due to its low weight and height this method is suitable for installing over existing timber floors as well as concrete floors.

Advantages: Much thinner than a standard system which reduces thermal mass and minimises increase in floor height in retro-fitted properties.

Disadvantages: More expensive to lay than the basic in-slab system.

2. European screed underfloor heating

Usually around 50mm thick, it has reduced thermal mass compared to in-slab and is totally insulated from the rest of the building and the outside meaning much lower losses, higher efficiency and faster response to controls.

Can be used for retrofit if the existing floor is strong enough and the raised floor level is acceptable.

Advantages: More efficiency and faster response to controls. Loses less heat through edge of the slab.

Disadvantages: More expensive than basic in-slab underfloor due to the two layers of concrete and greater amount of insulation.

4. Metal plate timber floor system

Alloy plates to spread heat are laid under floor boards or timber panel floors. The pipes are clipped into the plates which conduct the heat away from the pipes.

Insulation is positioned under the plates and pipes.

Advantages: Enables underfloor heating for timber floors without raising the floor level in existing buildings or building a floor to support a heavy screed in a new building.

Disadvantages: More expensive to lay than the basic in-slab floor.

Can underfloor heating be used with radiators on the same system?

Incorporating radiators into an underfloor system

Radiators and underfloor can be and are often used in the same system. Usually with the living areas kitchen and bathrooms, (hard floor areas) in underfloor, and the bedrooms with radiators.

This is easy to accomplish with a boiler as it can supply high temperature water to the radiators, and heat the floor via and thermostatic valve to reduce the temperature of the water going into the floor.

If a heat pump is used the radiators will have to be sized to run at a lower temperature, or two heat pumps used, one for the underfloor and a high temperature model for the radiators.



Incorporating underfloor into a radiator system

If a system is mostly radiators it is possible to have a small area of underfloor running through a return temperature limiting valve. This can cover about 15m² per valve.

This is a specifically designed thermostatic valve that allows the floor to be heated via higher temperature water but limits how hot it can get.



Choices of Heat Sources

Runs on your preferred fuel, no matter where you are

Underfloor heating can use **heat pumps** or **boilers** for supplying heat. Often the heat source is determined by the availability of fuels in the area.

Heat pumps work very efficiently and have low running costs at the lower operating temperatures of underfloor, typically 40°C, compared to radiators, typically 70°C.

High efficiency condensing boilers also run more efficiently at lower operating temperatures.

Unless a Baxi gas boiler is used, which has a special underfloor setting, a mixing valve is needed to reduce the temperature of the water going into the floor.



What are the running costs like for an underfloor heating system?

Running costs are a key issue for clients and one which can be very difficult to answer due to the variability in types of fuels and prices around New Zealand.

It is fairly easy to estimate unit running costs for different heat sources but annual totals vary greatly according to the size of house and lifestyle.

Running costs for different fuels

based on 20,000 kWh heat load which could include potable hot water or other heat loads such as swimming pools. *Costs calculated January 2012 for Christchurch, NG for Auckland*

Heat source	Annual heating cost (\$)	Unit heating cost (cents/kWh)
Baxi high efficiency gas boiler (NG)	1,801	9.0
Baxi high efficiency gas boiler (LPG)	3,489	17.5
Firebird Enviromax diesel boiler	3,004	15.0
Woodpecker wood pellet boiler	2,261	11.3
Air to water heat pump*	1,250	6.3
Ground Source heat pump*	875	4.4
Electric underfloor*	4,376	21.9

*Assumptions made about electricity pricing.

- No daily fixed charge is included in costings for single phase supplies as it is assumed this would be paid anyway, even without electrical heating.
- A prompt payment discount of 10% is applied
- Cost estimates are for single phase power only

3-Phase Electricity

For a heat pumps with an output greater than 14kW a three phase model would be needed.

The cost of connecting three phase power to a site that wouldn't otherwise have it needs to be taken into account. The tariff is likely to be commercial with a larger fixed cost element and reduced unit charge compared to a standard domestic tariff.

The connection and running costs will be particular to the site so it is not possible to give generalised advice.

It is possible to use single phase to three phase converters, or more than one single phase heat pump on site provided the total power (kW) drawn doesn't exceed the total power available for the site.



What level of control is there in a hydronic underfloor heating system?

Heating controls allow central heating systems to run totally automatically with virtually no input from the user other than to change or temporarily override the program. This is a major attraction of central heating as the house is always warm when you get up in the morning no matter what the weather, with minimal input from the users.



The basic functionality of the control system is to switch the heat source on and off, and to direct the heat to where it is needed by opening and closing valves, and/or switching pumps on and off.

Each system is designed according to the occupant's personal preferences. Some people prefer to run the system continuously all winter, only controlling the temperature of the water going into the floor; whilst others have thermostats in each room to precisely control the temperature according to a time schedule.

Multi zone control

It is possible to create different zones within a house which are automatically heated to different temperatures at different times but can still be overridden manual when a variation to the schedule is needed.

Having separate thermostats and time schedules for each room can make for a very complex control system; and potentially confusing if the owners haven't had central heating before.

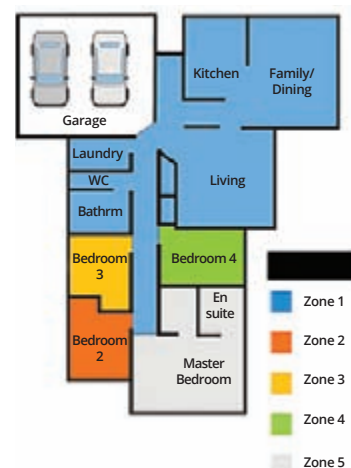

Slab temperature and response rate

The thermal mass of a heated slab or European screed system is large and so it takes a long time to heat up the floor slab. With these systems the slab becomes a heat store.

Controllers for high thermal mass systems monitor the actual floor slab temperature to keep it within a certain temperature range to improve response time.

When using a heat pump it is often only the temperature of the slab that is controlled by running the heat pump continuously at a fixed setpoint.

When the house is heated by the sun and the room temperature rises, the temperature difference between the slab and room is reduced, and so the heat transfer becomes minimal. To a large extent underfloor heating can be self regulating without the need for a room thermostat.

Design & installation issues to consider when planning underfloor heating

Manifold placement

Manifolds are a key part of the system and need to be placed as centrally as possible for optimal performance. Usually they are at the back of cupboards or in the laundry. Badly placed manifolds result in much more pipe being laid which adds to material and labour costs.

If there is one manifold at one end of the house pipes need to be run to the other end of the house and back reducing the length of pipe in the area being heated by that particular loop. This also produces a hot floor, usually in the hallway, where heating is least needed.

Underfloor manifolds are not a decorative feature and need to be hidden, however simply putting them out in the garage may well result in a poorer performing system. A better result for the customer is to find or create space for a manifold cabinet.

(In this case the manifold cabinet is inset into the wall reducing space taken up and allowing pipes to leave the manifold in either direction which is usually better than from one side only)

Manifold cabinets: Height = 600mm; depth 130mm; Length depends on number of loops and whether a mixing valve is used or not.

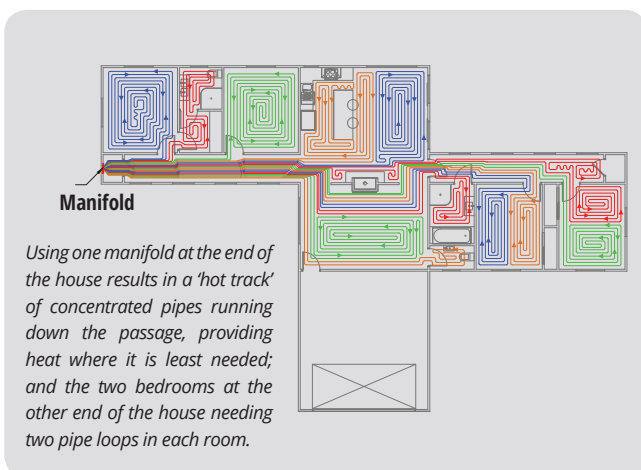

Bad manifold placement

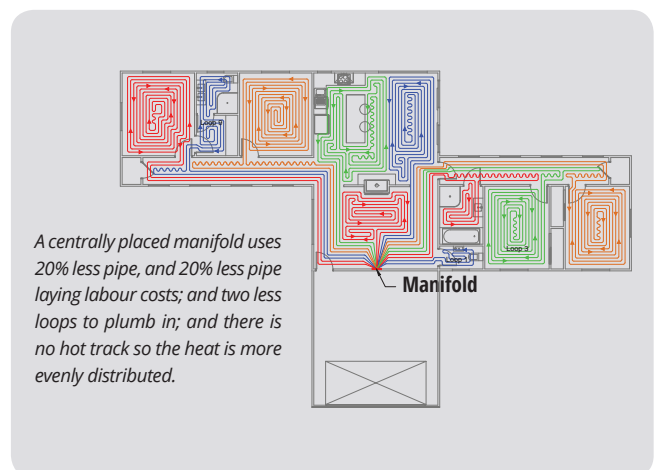

Good manifold placement

Floor coverings

Any floor covering on top of the heated part of the floor acts as a barrier to the heat flowing from the floor into the room. Thicker floor coverings such as carpet can be used, but the heating system has to be run at a higher temperature to get the required heat output, which is less efficient if a heat pump is used.

If the operating temperature has to be raised just for one room, the whole house will have to run at a higher temperature which increases running costs if a single heat pump is used.

A more expensive alternative is to use multiple heat pumps running at different temperatures. This is sometimes used for larger homes; or use supplementary heating in hard to heat rooms.

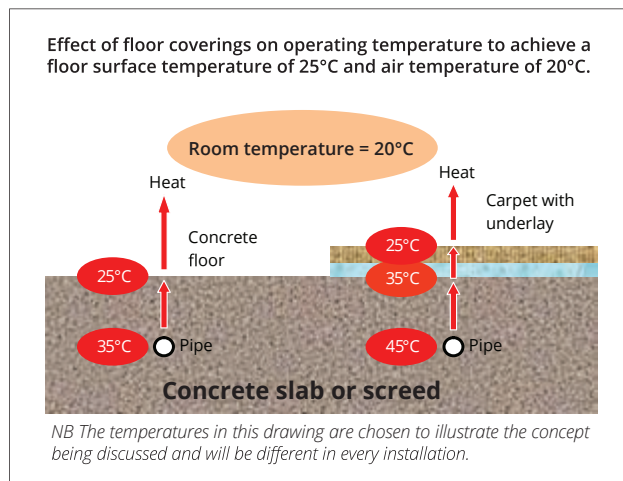

Heat loss from glazed areas

In a new house around 50% of the heat loss is through glazing alone. This is because standard aluminium framed double glazing loses heat at nearly 8 times the rate of a standard insulated wall. (See chart below).

A highly glazed room will have much more heat loss per square meter than the average heat loss for the house. As the heat flow from the floor is limited by the surface temperature it is possible even in a new house to design a room with a heat loss exceeding the heat that can be delivered by an underfloor system, particularly if a heat pump is used which limits operating temperature.

Such rooms often need a supplementary heat source to maintain temperature in very cold weather. Alternatively the thickness of floor coverings needs to be minimised.

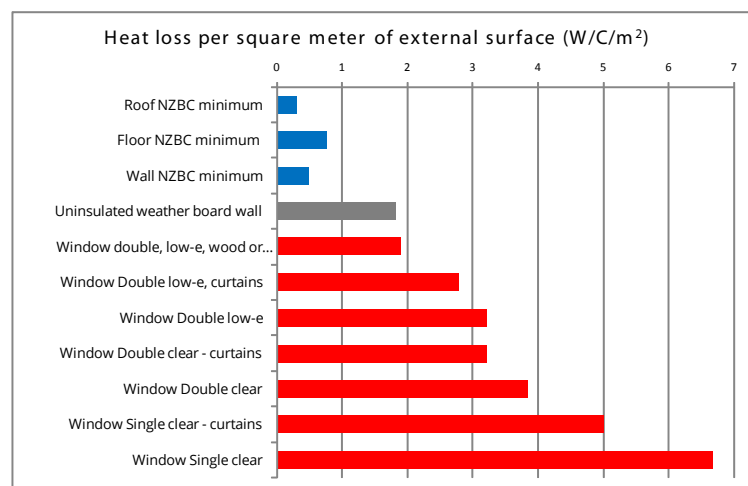

Design & installation issues to consider when planning underfloor heating (cont).

Timber & heated floors

To avoid cracking it is recommended that only properly dried timber is used or a timber floor product with an MDF backing or similar. Despite these issues it is very common to have timber coverings on heated floors with no problems at all.

It is preferable to glue timber to a concrete slab or screed and not to use foam backing.



Wall positioning and fixings to floor slab

Before the floor pipe loops are installed for a basic in-slab system the builder will need to mark out the position of the walls as it is usual to run the pipes to avoid going under walls so that the pipes are not punctured by fixings into the floor.

In this picture, right, the wall positions are marked in yellow and the pipe loop in the room goes in and out of the doorway.



A common cause of pipes being punctured is when wall positions are changed after the slab has been poured and are put over pipe runs. (This only applies to the basic in-slab method).

It is often preferable to have the pipes from a manifold radiating out either side of a wall. This requires the cooperation of all involved to make sure that part of the wall is not fixed into the floor slab where the pipes come into the manifold.

Concrete crack inducement and concrete cutting

If you are having a polished concrete floor thought needs to be given to where cuts are made and how this might impact on the pipes in the floor. This won't be a problem as long as the heating installer and builder can work together to make sure the heating system isn't compromised.

There are alternative systems to cutting which avoids any problems that might occur.

Some are crack inducing systems that are laid at the underside of the slab, such as the product shown in this picture (right).



Expansion Joints

An alternative is to use expansion joints such as the ones shown right.

When these are used it is important the pipes are laid before the joint is fixed in place, otherwise laying the pipe underneath will be very difficult.



Screed floors

The mix of the screed needs to be correct to prevent cracking; CHNZ can provide a specification on request.

Where edge insulation is used to prevent heat leaking out from the heated slab, as used in European screed and micro screed systems, the insulation will not provide a good fixing around the edge of a floor.

For practical reasons it is normal to cover the top of the edge insulation with the skirting board which is made the same thickness, as in the diagram below.

Wine cellars

Many homes these days have a 'wine cellar' which is often a small room rather than a real cellar. Designers need to be aware that even if the floor in that room doesn't have pipes in it, the room will still be heated by the heat spreading through the concrete slab from heated areas.

Design & installation issues to consider when planning underfloor heating (cont).

Thermal Bridging

When using an existing building element as a heat emitter, in this case the floor, there is a danger that heat loss to the outside can be greater than normal due to thermal bridging. This is caused by higher conductivity materials such as concrete running continuously between the inside and outside of the building creating a path for heat to flow out.

This mainly happens with pipes inset into the main floor slab as other methods tend to be thermally isolated from the outside of the house.

Pipes set in main slab

Heat flows from the main slab through the concrete to the outside. (Fig 1, above right)

To counter this heat loss, BRANZ recommend using a **thermal break of timber** between the main slab and the outer foundation. (Fig 2, right)

Screed floors (fig 3, below right) go one step further by having a completely insulated surface slab, cutting out heat loss through the slab edge entirely.

Further options for insulating around floor slabs can be found in the BRANZ Insulation Guide.

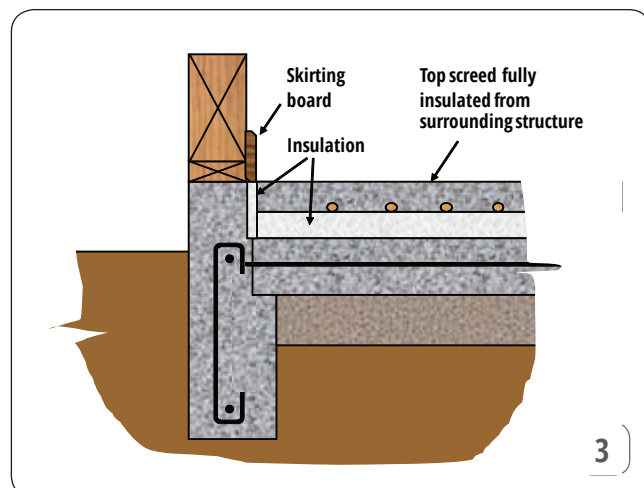
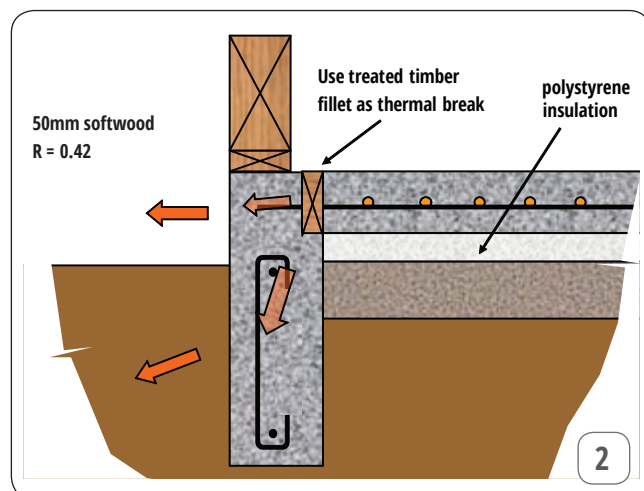
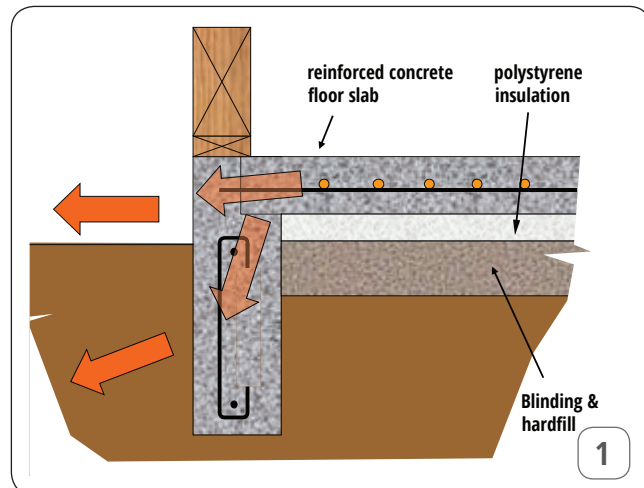

The following examples show other situations where thermal bridging increases heat loss, it will still be possible to heat the house, but more energy will be used.

Concrete Deck

If a concrete deck abuts a heated floor slab there will inevitably be some heat conducted through to the outside.

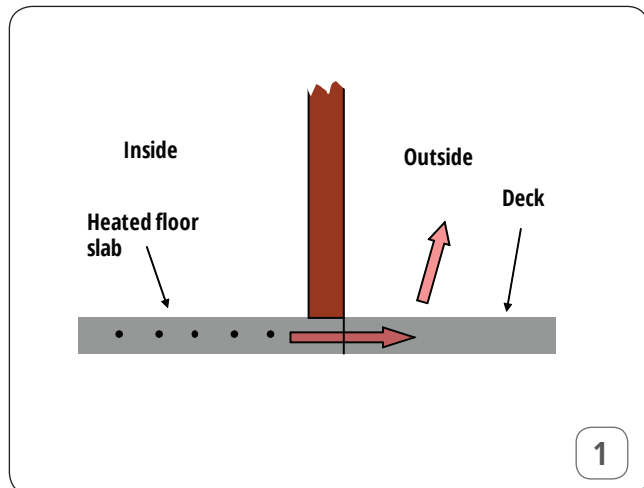

Tilt slab or concrete block walls

If the heated floor slab abuts a concrete exterior wall there will be enhanced heat transfer to the outside.

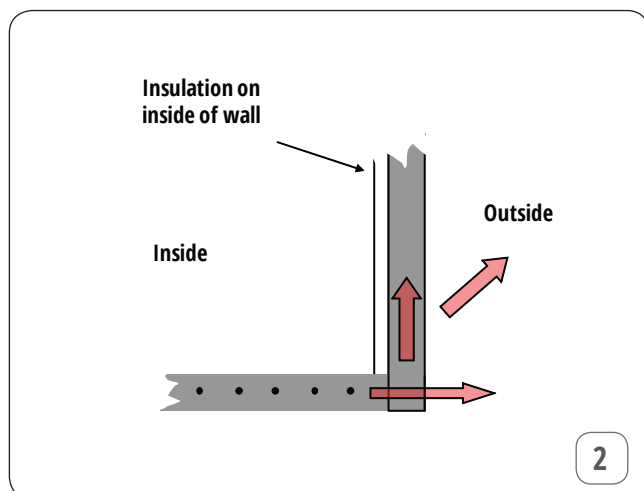

Unheated space below floor slab

If a heated floor slab has an unheated space below it, it must be insulated not only below the slab but around any supporting beams.

Any block wall supporting the heated slab will also conduct heat away to the outside.

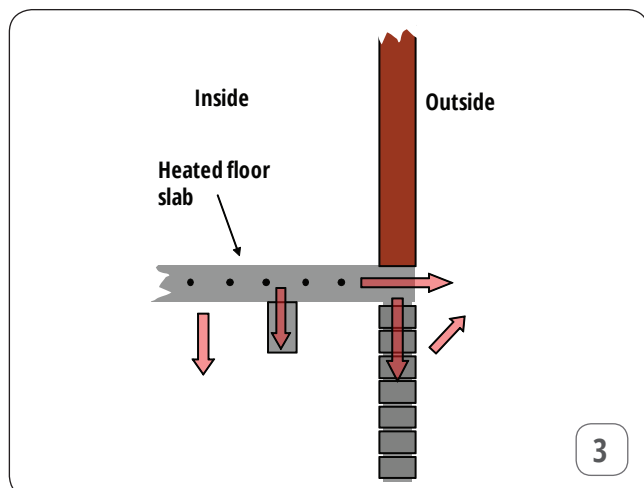

Design & installation process for underfloor heating systems

IN-SLAB HEATING

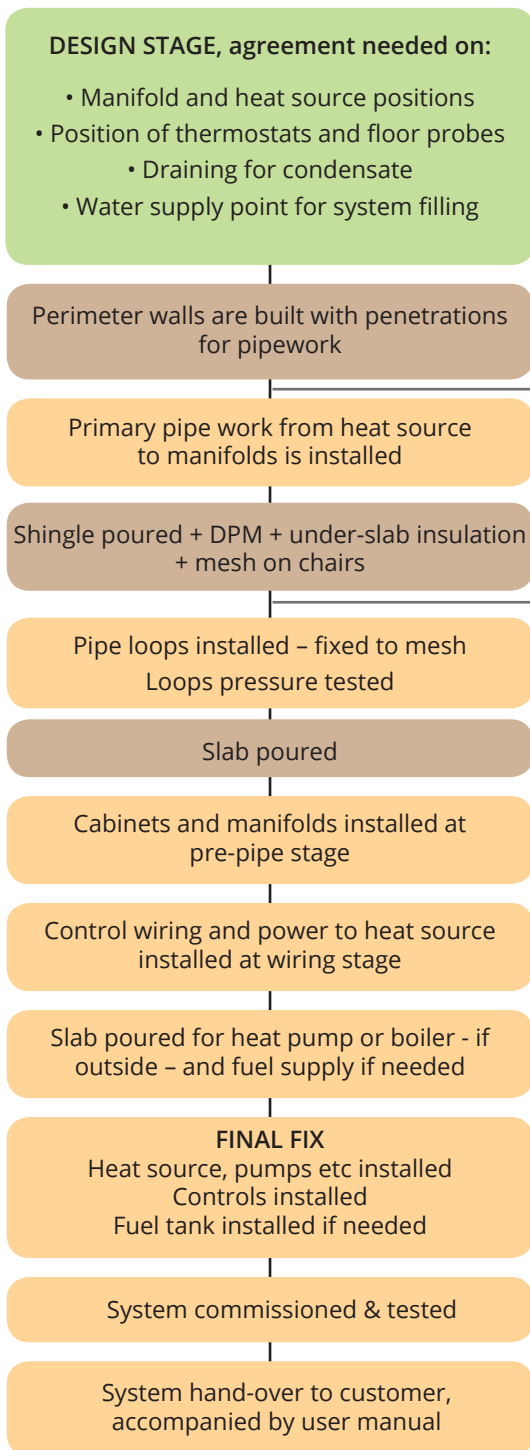

- Design Stage
- Installed by builder
- Installed by CHNZ

SCREED FLOOR HEATING

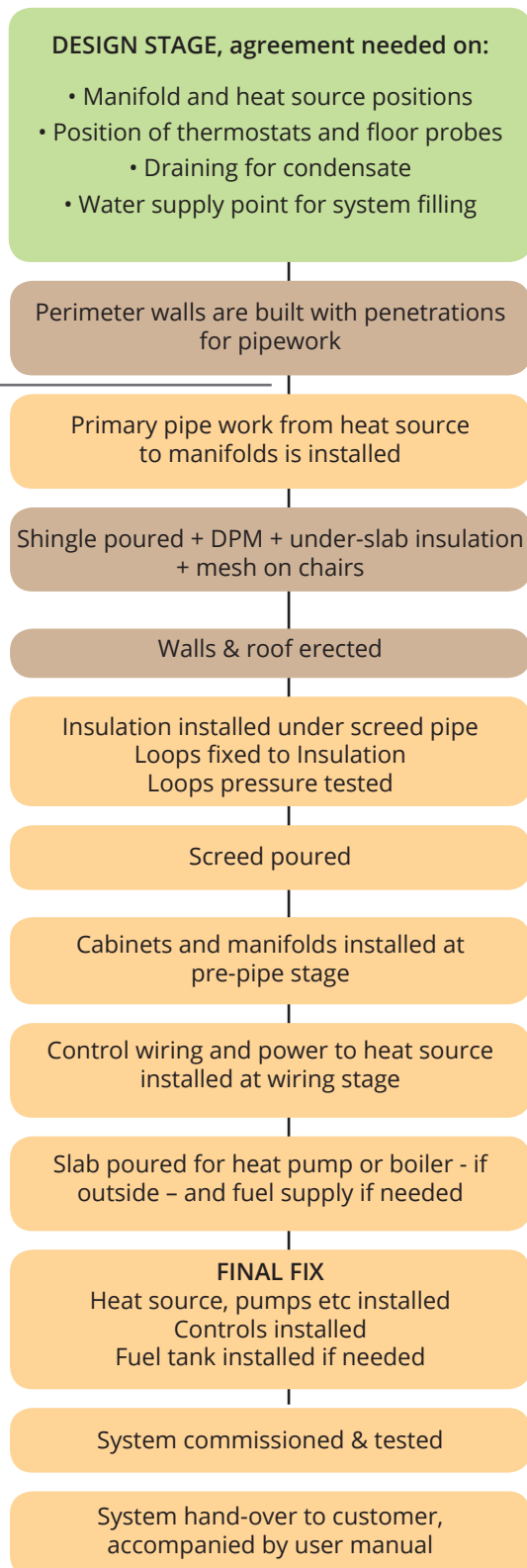

Builder marks out positions of heat source & manifolds

Builder marks out positions of manifolds & walls

Our Expertise

Design excellence - the Central Heating New Zealand difference

At Central Heating New Zealand we believe that good design should be at the heart of any heating system. That's why each underfloor system design starts with a heat loss calculation; something absolutely essential in ensuring the finished system will heat to the temperature and comfort level required.

To ensure that each of our system performs to exacting standards, Central Heating New Zealand employs qualified heating engineers and uses state of the art Computer Aided Design tools to produce designs for residential and commercial properties.

About Central Heating New Zealand

Central Heating New Zealand is the country's leading hydronic heating specialist, offering a full range of heat pump and boiler radiant systems to the public and to trade customers nationwide.

Central Heating New Zealand is certified with the International Ground Sourced Heat Pump Association, and has more than 40 geothermal heating systems installed and operated across New Zealand.

For more details on this or any of our products contact us on 03 357 1233 or email enquiries@centralheating.co.nz. Alternatively you can find out more about us and our products at centralheating.co.nz or viewing our product pages on productspec.net



Central Heating
NEW ZEALAND

PO Box 31-274, 52 Pilkington Way, Wigram, Christchurch 8042
Tel 03 357 1233 Fax 03 343 1236 enquiries@centralheating.co.nz
www.centralheating.co.nz