

**AIR CONDITIONING**



HEATING AND COOLING SOLUTIONS

# CEILING SYSTEMS



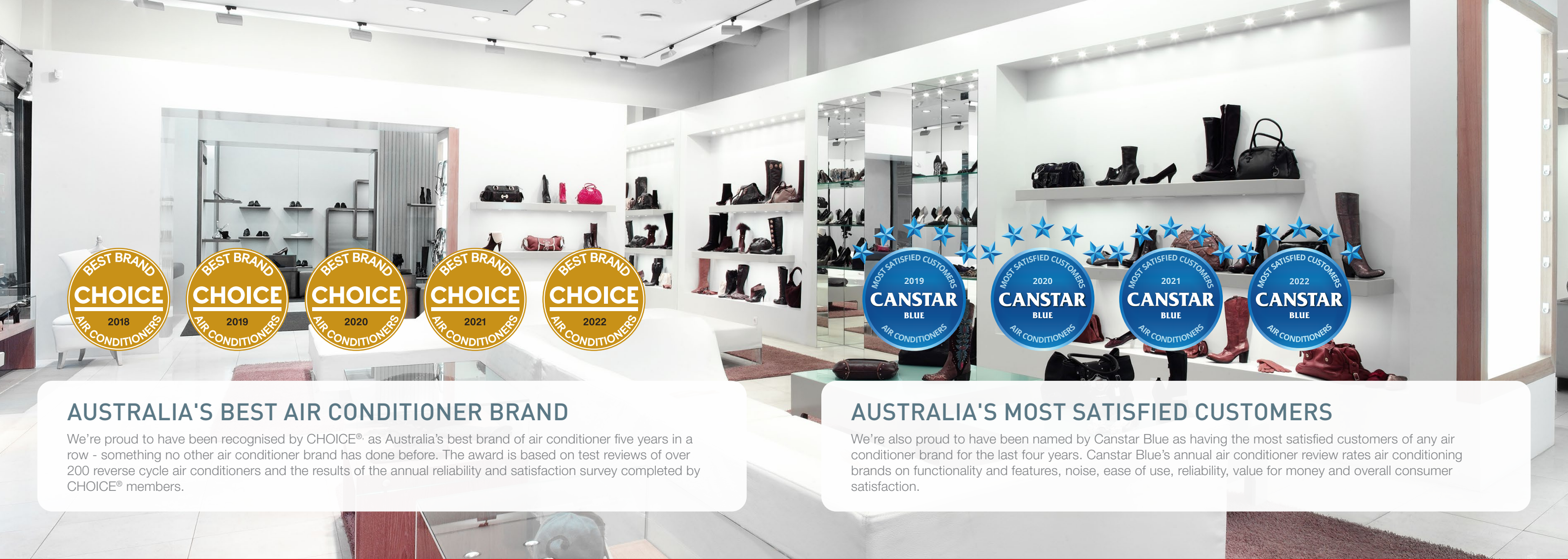

## AUSTRALIA'S BEST AIR CONDITIONER BRAND

We're proud to have been recognised by CHOICE® as Australia's best brand of air conditioner five years in a row - something no other air conditioner brand has done before. The award is based on test reviews of over 200 reverse cycle air conditioners and the results of the annual reliability and satisfaction survey completed by CHOICE® members.

## AUSTRALIA'S MOST SATISFIED CUSTOMERS

We're also proud to have been named by Canstar Blue as having the most satisfied customers of any air conditioner brand for the last four years. Canstar Blue's annual air conditioner review rates air conditioning brands on functionality and features, noise, ease of use, reliability, value for money and overall consumer satisfaction.

## MITSUBISHI HEAVY INDUSTRIES AIR CONDITIONERS AUSTRALIA

Mitsubishi Heavy Industries Air-Conditioners Australia (MHIAA) is one of Australia's leading suppliers of premium residential and commercial air conditioning systems. Delivering engineering excellence for over 130 years, the Mitsubishi Heavy Industries brand is instantly recognisable for quality and technological advancement.

With innovation central to both the organisation and the development of air conditioning systems, Mitsubishi Heavy Industries carries a strong philosophy of engineering products that are designed to improve the lives of those who use them and at the same time, create a sustainable future for our company and the world we live in.

## COMMITTED TO QUALITY

Standing behind the quality of our products, is our commitment to our customers and our after sales service guarantees. Along with the rigorous quality assurance testing carried out on all Mitsubishi Heavy Industries products, comprehensive warranties provide you with peace of mind and carry our commitment to quality.

## 5 YEARS PARTS AND LABOUR WARRANTY

Mitsubishi Heavy Industries Air conditioners Australia focuses solely on manufacturing high performance air conditioners for the Australian market. All our systems are of the highest quality and are backed by a full 5 year parts and labour warranty.



## EXCEEDING ENERGY PERFORMANCE STANDARDS

To comply with Australian standards and deliver the most efficient solutions possible to our customers, all Mitsubishi Heavy Industries Air conditioners Australia systems meet and exceed the Minimum Energy Performance Standards (MEPS).



# Key Features and Functions

Our ceiling systems come with a number of key convenient features and functions that are designed to ensure your comfort all year round. See page 9 for full list of all features and functions.



## HIGH POWER OPERATION

Provides 15mins of boosted power allowing you to quickly heat or cool your home before returning to normal operation. Perfect for when you first turn on the unit.



## WEEKLY TIMER

Set up to 4 timer operations a day (max 28 per week). Once set, the unit will turn on and off at the specified times of the day repeatedly.



## SLEEP TIMER

Allows you to set a pre-determined amount of time between 30 and 240 mins that your unit will operate for before switching off.



## SILENT OPERATION

Program periods where the unit will operate with reduced noise levels.



## BUILT-IN DRAIN PUMP

The built-in drain pump, which includes a lift of 850mm, allows greater flexibility with installation, offering a great solution for applications with limited space\*.



## VERTICAL AUTO SWING

Set the vertical louvres on your unit to move up and down continuously during operation. This function allows you to set the up/down swing position of the louvre to your preferred angle.

\*Applicable to FDT and FDTC products

# Our Technology

## IMPROVED HEAT EXCHANGER

Our new and improved heat exchanger has been developed to improve refrigerant distribution and increase the systems effectiveness. The new design features a larger heat exchange area, boosting the unit's overall efficiency.

## COATED PCB

To protect against humid weather a protective coating is applied to the circuit board in the outdoor unit, allowing it to withstand Australia's varying weather conditions and ensure the longevity of your system.

## BLUE FIN TECHNOLOGY

Mitsubishi Heavy Industries outdoor units are coated with specially formulated layers that assist in preventing the hydrophilicity effect and assists in reducing the corrosion rate of the aluminium section from harsh Australian weather conditions.

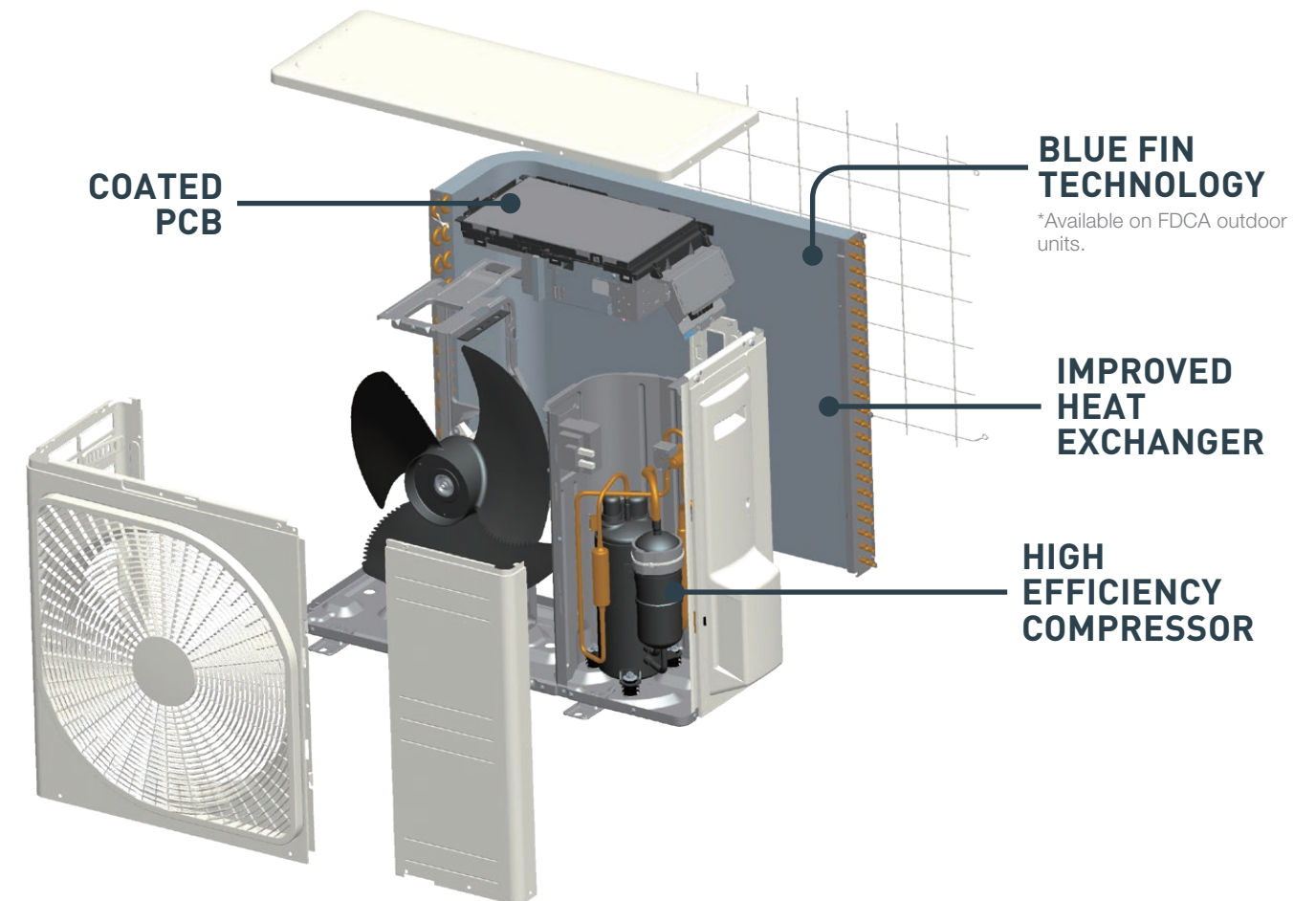

## HIGH EFFICIENCY COMPRESSOR

One of the key features that provides Mitsubishi Heavy Industries air conditioners with their powerful performance is our highly efficient compressor. Combined with a Neodymium motor that uses powerful, rare earth magnets, Mitsubishi Heavy Industries air conditioners can deliver a higher motor efficiency while producing much less operational noise.

## DC PAM INVERTER

The PAM control used in Mitsubishi Heavy Industries air conditioners helps minimise the loss of electricity and boost the efficiency by allowing the unit to reach the temperature quickly before slowing down the compressor. This allows the unit to save energy while maintaining a comfortable temperature in the room.

## WIDE OPERATION RANGE

With our advanced technology and high quality components, Mitsubishi Heavy Industries air conditioners can operate in ambient outdoor temperatures as low as -20°C in heating mode and as high as +50°C in cooling mode.

This permits the installation in areas where the temperature conditions can be considered extreme.



# FDT Series



## Control Solutions

### Wired



RC-EXZ3A RC-E5 RCH-E3

### Wireless



RCN-T-5BW-E2 (FINE SNOW)  
RCN-T-5BB-E2 (SHADOW BLACK)

### Motion Sensor



LB-T-5BW-E (FINE SNOW)  
LB-T-5BB-E (SHADOW BLACK)

See pg. 9 for full list of features and functions

# FDTC Series

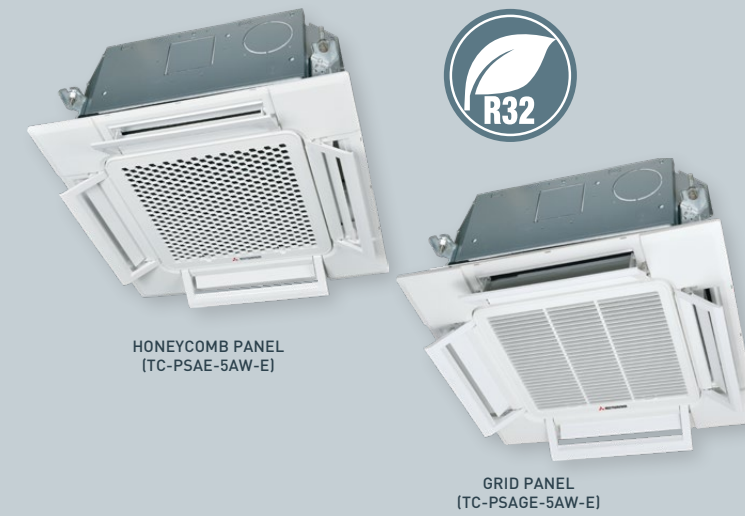

## Control Solutions

### Wired



RC-EXZ3A RC-E5 RCH-E3

### Wireless



RCN-TC-5AW-E3 (FINE SNOW)

### Motion Sensor



LB-TC-5W-E

See pg. 9 for full list of features and functions

## Four Way Ceiling Cassette 5.6kW | 7.1kW | 10.0kW | 12.1kW | 12.5kW | 14.0kW

### EASY MAINTENANCE

Easily check the drain pan by simply removing the corner panel.



Remove cover lid

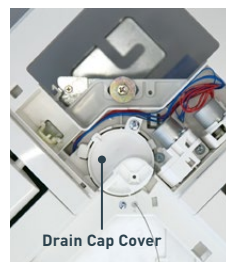

Drain Cap Cover

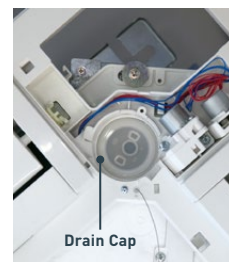

Drain Cap

Remove drain cap cover and check the condition. To clean, firstly remove the rubber plug to drain water before removing the drain cap.

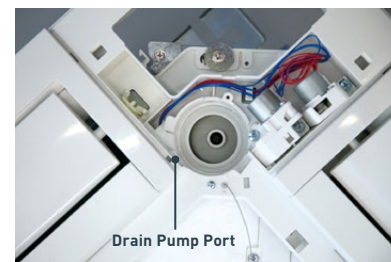

Drain Pump Port

Clean up the area around the drain pump port.

### DRAUGHT PREVENTION PANEL

The Draught Prevention Panel utilises 4 specially designed louvres to direct airflow horizontally along the ceiling, eliminating uncomfortable draughts.

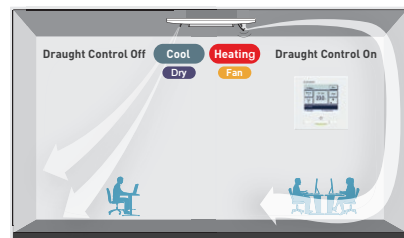

### INDIVIDUAL LOUVRE CONTROL

Individually control each of the four louvre's position, to deliver varied airflow in all directions.



### BUILT-IN DRAIN PUMP

Drain can be discharged upwards by 850mm from the ceiling surface allowing for flexible piping layout to suit many applications.

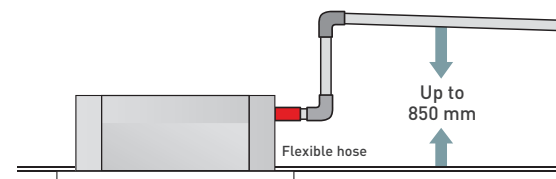

## Compact Four Way Ceiling Cassette 2.5kW | 3.5kW | 5.0kW | 5.6kW



### FLAT PANEL AND GRILL DESIGN

Weighing only 14kgs, with a main body height of only 248mm and fascia panel of only 10mm, the new FDTC series can be easily installed in a huge range of applications where space may be limited.

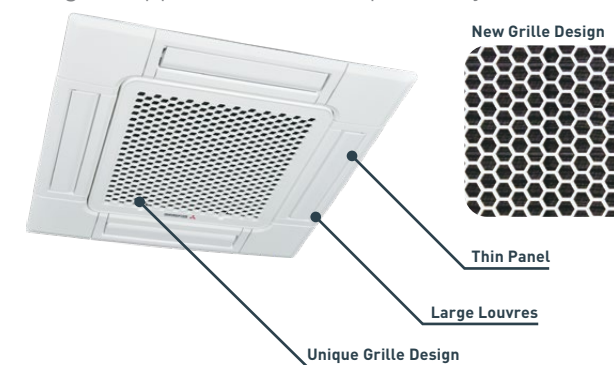

### QUIETER OPERATION

New and improved turbo fan and heat exchanger design has allowed for a reduction in operation noise.

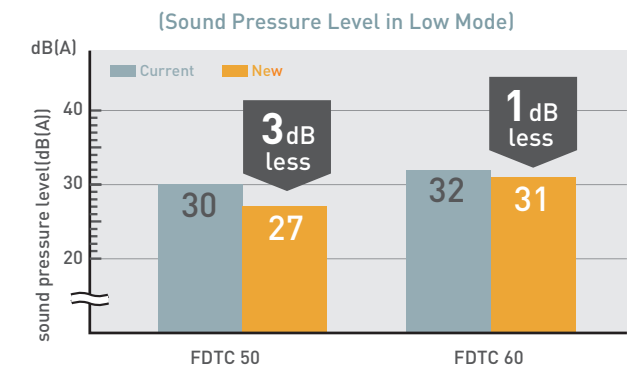

### DRAUGHT PREVENTION PANEL

The Draught Prevention Panel utilises 4 specially designed louvres to direct airflow horizontally along the ceiling, eliminating uncomfortable and annoying draughts.

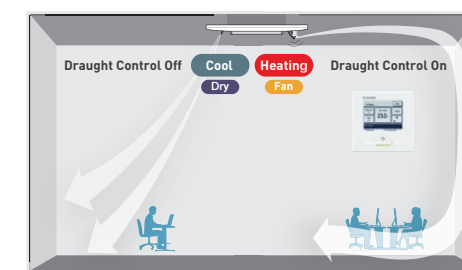

### MOTION SENSOR

Monitors human activity in the room and adjusts temperature setting to produce optimum temperature and save energy. Will turn unit to standby mode to also save energy.

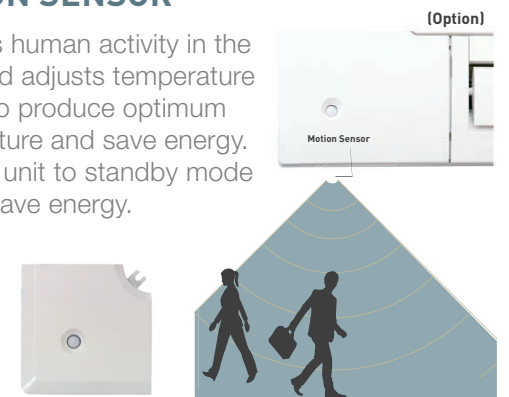

# FDE Series

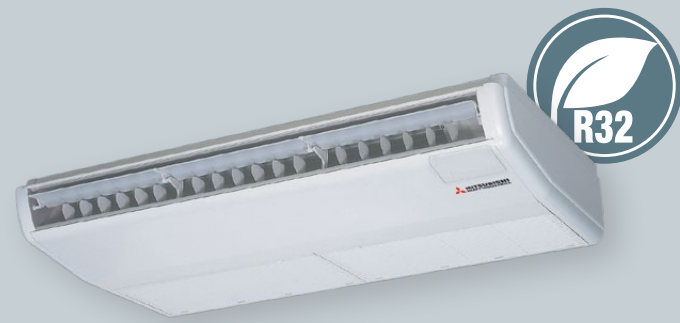

## Control Solutions

### Wired



RC-EXZ3A

RC-E5

RCH-E3

### Wireless



RCN-E-E3

### Motion Sensor



LB-E

See pg. 9 for full list of features and functions

## Ceiling Suspended 7.1kW | 10.0kW | 12.1kW | 12.5kW | 14.0kW

### ADJUSTABLE LOUVRES

Set the louvres in a number of fixed positions for effective air distribution.

\*Not available with RCH-E3 controller

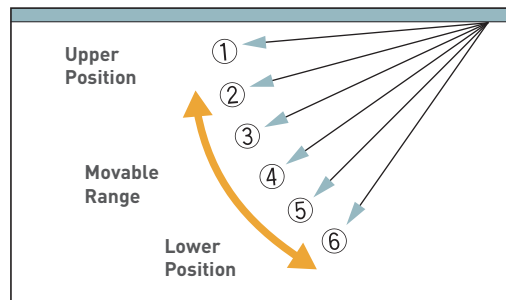

### SLIM LIGHTER DESIGN

By reducing the number of fan motors, the FDE series has been able to adopt a slim and more lightweight design.

	Previous (VF)		Current (VH)	
FDE71	37	→	33	4kg less!
FDE100	49	→	43	6kg less!
FDE125	49	→	43	6kg less!
FDE140	49	→	43	6kg less!

### REDUCED OPERATION NOISE

By adjusting airflow volume and decreasing pressure loss by utilising one single fan motor, the FDE series boasts some of the industry's lowest operation noise levels.

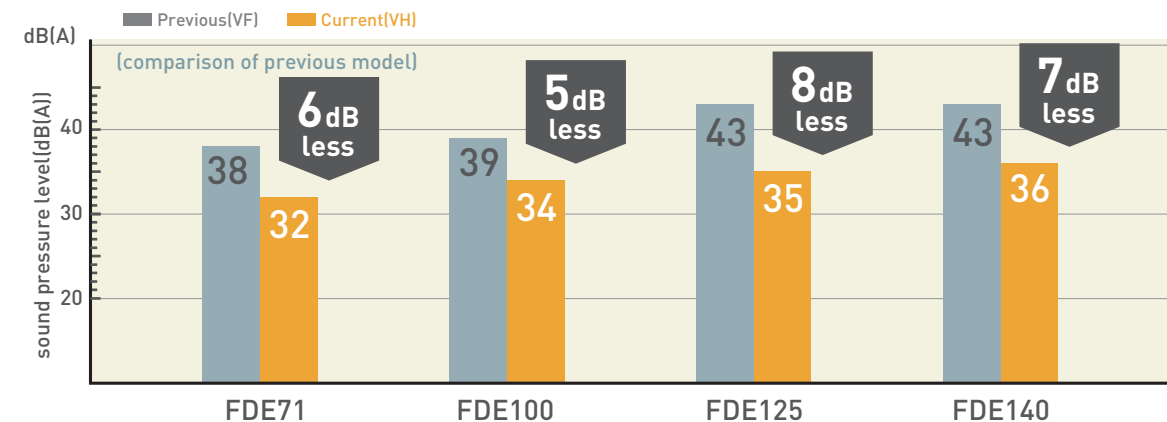

# Features and Functions

	FUNCTION	DESCRIPTION	FDT	FDTC	FDE
AIRFLOW	Louvre Control System	Set the upper and lower limit positions of the louvre at each air outlet individually, providing you with complete control over interior air flow.	●	●	●
	Automatic Fan Speed	The unit's on-board microcomputer continuously monitors the room's air temperature and adjusts the air flow automatically.	●	●	●
	Vertical Auto Swing	The vertical louvres on your unit will move up and down continuously during operation. This function allows you to set the up/down swing position of the louvre to your preferred operation angle.	●	●	●
CLEAN AIR	Air Filter	The air filter in the unit traps and removes airborne dust particles and other allergens to provide you with a clean air function.	●	●	●
	Filter Sign	Warning that alerts you to when the filter needs to be cleaned.	●	●	●
	Outside Air Intake	Provides clean fresh air into the room through the external air intake, avoiding the constant recycling of internal air.	●	● Optional	●
MAINTENANCE	Self Diagnostics	The internal microcomputer automatically runs a diagnostic of the system in the event of a malfunction. This enables your authorised dealer to isolate and repair any issues.	●	●	●
	Built-in Drain Pump	The built-in drain pump, which includes a lift of 850mm, allows greater flexibility with installation, offering a great solution for applications with limited space.	●	●	●
	Set Temperature Auto Return*	Allows you to program a preferred set temperature that the unit will return to each time it is operated.	●	●	●
ENERGY SAVING	Home Leave Operation*	Ensures that when the room is unoccupied for long periods of time, the unit will maintain a moderate indoor temperature, avoiding extremely hot or cool temperatures.	●	●	●
	Peak-Cut Timer*	Preset the capacity limit during certain periods of the day, minimising energy consumption during peak billing times, thus reducing operation costs.	●	●	●
OPERATION	Hi Power Operation*	Provides 15mins of boosted heating or cooling power before returning to normal operation. Perfect for when first using the unit.	●	●	●
	Silent Operation	Allows you to program periods where the unit will operate with reduced noise levels, perfect for night time and an uninterrupted sleep	●	●	●
	Automatic Operation	Automatically selects the required heating or cooling function based on the current room conditions.	●	●	●
	Weekly Timer	Set your unit to turn on and off automatically on a weekly basis to suit your usual room usage on each day.	●	●	●
	Sleep Timer	Set a pre-determined amount of time between 30 and 240 mins that your unit will operate for before switching off.	●	●	●
	Function Switch*	From the six available functions on the unit, this function allows you to set two functions to operate automatically. (Note: this is not available when a centralised remote control is connected).	●	●	●

\*Functions can only be enabled using RC-EXZ3A wired controller.

On/off timer, weekly timer and sleep timer are disabled if Wi-Fi accessory connected. Similar functions can be set via the AC Cloud application.



# Optional Control Solutions

## WIRED CONTROLLERS



### RC-EXZ3A

- Large, 3.8" backlit LCD touch screen with easy to navigate menu.
- Control the set temperature, operation mode and fan speed.
- Access timer and scheduling functions.
- Access additional features including Home Leave mode, Silent Mode, High Power mode plus many more.
- Multi-language display (6 languages).



### RC-E5

- Easy to use controller with LCD Display.
- Control the set temperature, operation mode and fan speed.
- Access timer and scheduling functions.
- Access service, maintenance and technical data.



### RCH-E3

- Simple, easy to use controller.
- Control the set temperature, operation mode and fan speed.

## WIRELESS KITS AND REMOTE CONTROLS

### KEY FEATURES

- Hi Power Mode
- Energy Saving Mode
- Home Leave Mode
- Silent Mode
- On / Off Timer
- Child Lock

### FDT



RCN-T-5BW-E2 (FINE SNOW) RCN-T-5BB-E2 (SHADOW BLACK)

### FDTC



RCN-TC-5AW-E3 (FINE SNOW)

### FDE

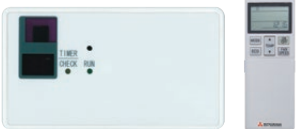

RCN-E-E3

## THERMISTOR (OPTIONAL)

Used in cases where the sensor in the indoor unit or the remote control can not detect the room temperature correctly or individual remote control in each room is not required.



SC-THB-E3

## WI-FI ADAPTOR

### MH-RC-WIFI-1B

The MH-RC-WIFI-1B allows you to control your system via your smart device or browser including on/off, temperature, mode and fan speed settings.



Device to be installed by a qualified licensed person, and to a location not susceptible to temperatures above 40°C.

# WI-FI SOLUTION



## Control Your Air **Your** Way

- CONTROL YOUR AIR CONDITIONER USING YOUR SMARTPHONE, TABLET OR DESKTOP VIA EASY TO USE AC CLOUD CONTROL APP\*.
- CONTROL YOUR AIR CONDITIONER USING VOICE COMMAND VIA YOUR GOOGLE OR AMAZON SMART DEVICE\*\*.
- SET UP 'FAVOURITE' SCENES AND ACTIVATE THEM WITH A SINGLE TAP.
- SET YOUR SYSTEM TO RESPOND TO THE WEATHER, YOU ARRIVING HOME, CALENDAR EVENTS AND MORE\*\*.
- RECEIVE INSTANT NOTIFICATIONS AND EMAIL UPDATES\*\*.

\*Requires MH-RC-WIFI-1B Wi-Fi adaptor (sold separately)

\*\*In conjunction with IFTTT and other apps (must be downloaded separately).

Note: Some additional functions may not be available via AC Cloud Control app. The system's On/Off timer, weekly timer and sleep timer are disabled if a Wi-Fi accessory is connected. Similar functions can be set via the AC Cloud App.

## AC Cloud Control



### Compatible with



Controlling your device with AC Cloud Control app requires aforementioned Wi-Fi adaptors and working internet or Wi-Fi connection. Google Account required for use with Google devices. Features and services may change without notice. Google is a trademark of Google LLC.

PRODUCT SPECIFICATIONS

# FDT SERIES

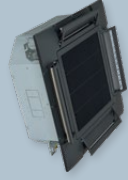

FDT60-140VH



SRC60Z5XA-W



FDCA71VNX-W,  
FDC100VNP-W,  
FDCA100VNP-W



FDCA100VNA-W, FDCA100VSA-W,  
FDC125VNP-W, FDCA125VNP-W



FDCA140VNX-W,  
FDCA125VSA-W,  
FDCA140VSK-W



Images are for illustration purposes and actual product labels may differ.

CAPACITY	5.6kW		7.1kW		10.0kW		10.0kW		12.1kW		12.1kW		12.5kW		14.0kW		10kW		12.5kW		14.0kW		
	Set	Indoor	Outdoor	Power Source (Outdoor Unit)	Set	Indoor	Outdoor	Power Source (Outdoor Unit)	Set	Indoor	Outdoor	Power Source (Outdoor Unit)	Set	Indoor	Outdoor	Power Source (Outdoor Unit)	Set	Indoor	Outdoor	Power Source (Outdoor Unit)	Set	Indoor	Outdoor
*Operation Data	Nominal Capacity (Range)	5.6 (1.1-6.3)	7.1 (3.2-8.0)	10.0 (4.0-11.2)	10.0 (2.1 - 10.2)	10 (1.7 - 10.4)	10 (1.7 - 10.4)	12.1 (5.0-12.1)	12.1 (5.0-12.1)	12.1 (4.0-13.3)	12.1 (4.0-13.3)	12.5 (3.5-14.0)	14.0 (3.5-16.0)	10.0 (4.0-11.2)	11.2 (4.0-12.5)	14.0 (2.7-18.0)	12.5 (3.5-14.0)	14.0 (2.7-18.0)	10.0 (4.0-11.2)	11.2 (4.0-12.5)	14.0 (2.7-18.0)	12.5 (3.5-14.0)	14.0 (2.7-20.0)
	Power Consumption	1.33	1.69	2.73	2.84	2.33	2.33	2.84	2.84	3.69	3.69	3.21	3.87	2.73	2.73	3.81	3.81	2.73	2.73	3.81	3.81	3.87	4.20
Installation Data	Refrigerant (R32)	1.3	2.75	3.3	1.7	1.7	1.7	1.7	1.7	2.25	2.25	2.25	2.25	2.25	3.3	3.3	3.3	3.3	3.3	3.3	4.0	4.0	
	Refrigerant Piping	Ø6.35	Ø9.52	Ø15.88	Ø15.88	Ø15.88	Ø15.88	Ø15.88	Ø15.88	Ø15.88	Ø15.88	Ø15.88	Ø15.88	Ø15.88	Ø15.88	Ø15.88	Ø15.88	Ø15.88	Ø15.88	Ø15.88	Ø15.88	Ø15.88	Ø15.88
Controller	Max Vertical Height Diff. Between O.U. and I.U.	20 (O.U. above I.U.) / 30 (O.U. below I.U.) / 50 (O.U. above I.U.) / 20 (O.U. below I.U.)	30	30	30	30	30	30	30	30	30	30	30	30	30	30	30	30	30	30	30	30	30
	Max Vertical Height Diff. Between O.U. and I.U.	20 (O.U. above I.U.) / 30 (O.U. below I.U.) / 50 (O.U. above I.U.) / 20 (O.U. below I.U.)	30	30	30	30	30	30	30	30	30	30	30	30	30	30	30	30	30	30	30	30	30

Operation	Indoor Air Temperature		Outdoor Air Temperature		Standards
	DB	WB	DB	WB	
Cooling	27°C	19°C	35°C	24°C	AS/NZ 3823.2
Heating	20°C	-	7°C	6°C	

(1) The data is measured at the conditions mentioned in the table to the left.  
 (2) The air conditioner is manufactured and tested in conformity with the AS/NZS.  
 (3) Sound level indicates the value in an anechoic chamber. During operation these values are somewhat higher due to ambient conditions.  
 (4) Select the breaker size according to applicable national standard.  
 (5) The operation data indicates when the air-conditioner is operated at 240V/50Hz.  
 (6) Reducer set Ø9.52 -> Ø6.35 is included in the outdoor unit as accessory for FDC100VNP-W & FDCA100VNP-W

PRODUCT SPECIFICATIONS

# FDTC SERIES



FDTC25-60VH



SRC25-35Z5A-W



SRC50-60Z5XA-W

Images are for illustration purposes and actual product labels may differ.

CAPACITY	2.5kW		3.5kW		5.0kW		5.6kW	
	Set	Indoor	Outdoor	Power Source (Outdoor Unit)	Set	Indoor	Outdoor	Power Source (Outdoor Unit)
*Operation Data	Nominal Capacity (Range)	2.5 (0.9-3.5)	3.5 (0.9-4.3)	4.25 (0.9-4.6)	5.0 (1.1 - 5.6)	5.6 (1.1-6.3)	6.7 (0.6-6.7)	5.6 (1.1-6.3)
	Power Consumption	0.54 (0.18-0.89)	0.77 (0.18-1.36)	0.91 (0.18-1.37)	1.08 (0.19 - 1.33)	1.40	1.73	2.14
Installation Data	Refrigerant (R32)	0.78	1.5	1.5	1.5	1.5	1.5	1.5
	Refrigerant Piping	Ø6.35	Ø9.52	Ø9.52	Ø9.52	Ø9.52	Ø9.52	Ø9.52
Controller	Max Vertical Height Diff. Between O.U. and I.U.	20	20	20	20	20	20	20
	Max Vertical Height Diff. Between O.U. and I.U.	10 (O.U. above I.U.) / 10 (O.U. below I.U.)	10 (O.U. above I.U.) / 10 (O.U. below I.U.)	10 (O.U. above I.U.) / 10 (O.U. below I.U.)	20 (O.U. above I.U.) / 20 (O.U. below I.U.)	20 (O.U. above I.U.) / 20 (O.U. below I.U.)	20 (O.U. above I.U.) / 20 (O.U. below I.U.)	20 (O.U. above I.U.) / 20 (O.U. below I.U.)

\*The data is measured under the following conditions (AS / NZS 3823.2). Cooling: Indoor temp. of 27°CDB, 19°CWB, and outdoor temp. of 35°CDB. Heating: Indoor temp. of 20°CDB, and outdoor temp. of 7°CDB, 6°CWB.



# FDE SERIES



FDC100VNP-W  
FDE71-140VH



FDC125VNP-W  
FDC100VNP-W



FDC100VNA-W, FDC100VSA-W  
FDC125VNP-W, FDC100VNP-W



FDC125-140VSK-W  
FDC125-140VSK-W

Images are for illustration purposes and actual product labels may differ.

CAPACITY		7.1kW	10.0kW	10.0kW	10.0kW	12.1kW	12.1kW	12.5kW	14.0kW	10kW	12.5kW	14.0kW	14.0kW
Set	Indoor	FDE71VNX-W FDE71VH	FDE100VNA-W FDE100VH	FDE100VNP-W FDE100VH	FDE100VNP-W FDE100VH	FDE125VNP-W FDE125VH	FDE125VNP-W FDE125VH	FDE125VNP-W FDE125VH	FDE140VNX-W FDE140VH	FDE100VSA-W FDE100VH	FDE125VNA-W FDE125VH	FDE100VSA-W FDE100VH	FDE140VSA-W FDE140VH
	Outdoor	FDCA71VNX-W	FDCA100VNA-W FDC100VNP-W	FDC100VNP-W	FDC100VNP-W	FDC125VNP-W	FDC125VNP-W	FDC125VNP-W	FDCA140VNX-W FDC140VNP-W	FDCA100VSA-W FDC100VNP-W	FDC125VNA-W FDC125VSK-W	FDCA100VSA-W FDC100VNP-W	FDCA140VSA-W FDC140VSK-W
Power Source (Outdoor Unit)		1 Phase 240V 50Hz											
Nominal Capacity (Range)	Cooling T1	7.1 (3.2-8.0)	10.0 (4.0-11.2)	10.0 (2.1 -10.2)	10.0 (2.1 -10.2)	12.1 (5.0-12.1)	12.1 (5.0-12.1)	12.5 (3.5-14.0)	14.0 (3.5-16.0)	10.0 (4.0-11.2)	12.5 (3.5-14.0)	14.0 (3.5-16.0)	14.0 (3.5-16.0)
	Heating H1	8.0 (3.6-9.0)	11.2 (4.0-12.5)	10 (1.7 - 10.4)	10 (1.7 - 10.4)	12.1 (4.0-13.3)	12.1 (4.0-13.3)	14.0 (2.7-17.0)	16.0 (2.7-18.0)	11.2 (4.0-12.5)	14.0 (2.7-18.0)	16.0 (2.7-18.0)	16.0 (2.7-20.0)
Power Consumption	Cooling T1	7.40	10.00	7.60	7.60	7.90	7.90	14.90	15.50	10.00	14.90	15.50	15.50
	Heating H1	1.87	2.85	3.00	3.00	3.88	3.88	3.34	4.08	2.85	3.77	4.41	4.08
Maximum Power Consumption	Cooling T1	4.11	6.40	4.46	4.46	4.75	4.75	7.10	7.10	10.20	8.90	8.90	8.90
	Heating H1	8.3	13.8	12.8	12.8	16.3	16.3	14.7	17.9	4.6	6.3	6.3	6.5
Running Current	Cooling T1	8.3	12.4	10.1	10.1	13.9	13.9	16.4	19.4	4.0	6.3	6.3	7.2
	Heating H1	5, 19.1	5, 24	5, 19	5, 19	5, 18	5, 18	5, 27	5, 14	5, 15	5, 14	5, 14	5, 14
Inrush Current, Maximum Current	Cooling T1	3.80	3.51	3.33	3.33	3.12	3.12	3.43	3.43	3.51	3.75	3.75	3.43
	Heating H1	4.28	4.41	4.24	4.24	3.67	3.67	3.74	3.63	4.41	3.74	3.74	3.63
Sound Power Level (JIS C9612)	Outdoor	66	70	68	68	73	73	70	71	70	70	70	71
	Indoor	P-Hi:47 Hi:41 Me:37 Lo:32	P-Hi:48 Hi:43 Me:38 Lo:34	P-Hi: 48 Hi: 43 Me:38 Lo: 34	P-Hi: 48 Hi: 43 Me:38 Lo: 34	P-Hi: 48 Hi: 45 Me: 40 Lo: 35	P-Hi: 48 Hi: 45 Me: 40 Lo: 35	P-Hi: 48 Hi: 45 Me: 40 Lo: 35	P-Hi:48 Hi:45 Me:40 Lo:36	P-Hi:48 Hi:43 Me:38 Lo:34	P-Hi:48 Hi:45 Me:38 Lo:36	P-Hi:48 Hi:45 Me:40 Lo:35	P-Hi:533 Hi:483 Me:383 Lo:283
Sound Pressure Level (JIS C9612)	Outdoor	51	55	54	54	57	57	54	54	55	54	54	54
	Indoor	210x1320x690	250x1620x690	250x1620x690	250x1620x690	250x1620x690	250x1620x690	250x1620x690	250x1620x690	250x1620x690	250x1620x690	250x1620x690	250x1620x690
External dimensions (HXWD)	Outdoor	750x880(+88)x340	845x970x370	750x880(+88)x340	750x880(+88)x340	845x970x370	845x970x370	845x970x370	845x970x370	845x970x370	845x970x370	845x970x370	845x970x370
	Indoor	33	43	43	43	43	43	43	43	43	43	43	43
Net weight	Outdoor	60	77	57	57	73	73	67	73	78	99	99	99
	Indoor	P-Hi:333 Hi:267 Me:217 Lo:167	P-Hi:533 Hi:433 Me:350 Lo:275	P-Hi:533 Hi:433 Me:350 Lo:275	P-Hi:533 Hi:433 Me:350 Lo:275	P-Hi:533 Hi:483 Me:383 Lo: 283	P-Hi:533 Hi:483 Me:383 Lo: 283	P-Hi:533 Hi:483 Me:383 Lo:283	P-Hi:567 Hi:483 Me:383 Lo:275	P-Hi:533 Hi:433 Me:350 Lo:275	P-Hi:533 Hi:483 Me:383 Lo:283	P-Hi:533 Hi:483 Me:383 Lo:283	P-Hi:567 Hi:483 Me:383 Lo:283
Refrigerant (R32)	Quantity	2.75	3.3	1.7	1.7	2.25	2.25	2.25	4.0	3.3	4.0	4.0	4.0
	Pre-Charged to Pipe	30	30	15	15	15	15	15	30	30	30	30	30
Refrigerant Piping	Liquid Line	Ø9.52	Ø9.52	**Ø6.35	**Ø6.35	Ø9.52	Ø9.52	Ø9.52	Ø9.52	Ø9.52	Ø9.52	Ø9.52	Ø9.52
	Gas Line	Ø15.88	Ø15.88	Ø15.88	Ø15.88	Ø15.88	Ø15.88	Ø15.88	Ø15.88	Ø15.88	Ø15.88	Ø15.88	Ø15.88
Installation Data	Connection Method	Flare Connection											
	Maximum Pipe Length (One Way)	50	50	30	30	30	30	100	100	50	100	100	100
Controller	Max Vertical Height Diff. Between O.U. and I.U.	30 (O.U. above I.U.) / 50 (O.U. above I.U.) / 15 (O.U. below I.U.)											
	Motion Sensor (Optional)	RC-E6, RC-EXZ3A, RC-H-E3 or RCN-E-E3											
Demand Response (AS4755)	Cooling	Yes	Yes	No	Yes	No	Yes	Yes	Yes	Yes	Yes	Yes	Yes
	Heating	-15 to 50	-15 to 50	-15 to 46	-15 to 46	-15 to 46	-15 to 46	-15 to 50	-15 to 50	-15 to 50	-15 to 50	-15 to 50	-15 to 50
Outdoor air temperature (upper, lower limits)	Cooling	-20 to 20	-20 to 20	-15 to 20	-15 to 20	-15 to 20	-15 to 20	-15 to 20	-15 to 20	-15 to 20	-15 to 20	-15 to 20	-15 to 20
	Heating	-20 to 20	-20 to 20	-15 to 20	-15 to 20	-15 to 20	-15 to 20	-15 to 20	-15 to 20	-15 to 20	-15 to 20	-15 to 20	-15 to 20

\*The data is measured under the following conditions (AS / NZS 3823.2). Cooling: Indoor temp. of 27°CDB, 19°CWB, and outdoor temp. of 20°CDB, and outdoor temp. of 7°CDB, 6°CWB.  
\*\*Reducer set Ø9.52 -> Ø6.35 is included in the outdoor unit as accessory for FDC100VNP-W.

# EXTERIOR DIMENSIONS FDT SERIES

## FDT60-71VH

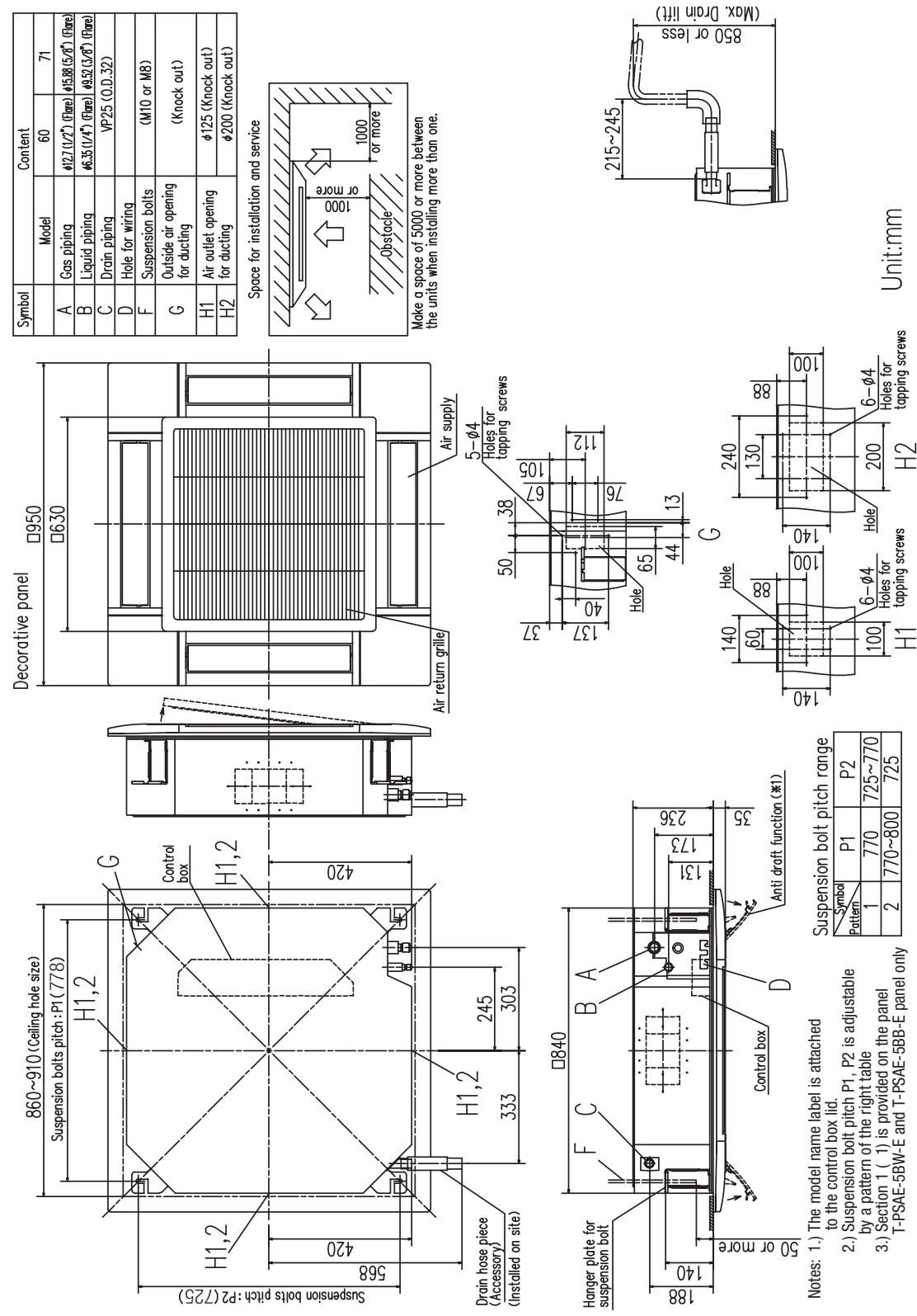

Notes:

- The model name label is attached to the control box lid.
- Suspension bolt pitch P1, P2 is adjustable by a pattern of the right table
- Section 1 ( 1 ) is provided on the panel T-PSAE-6BW-E and T-PSAE-6BB-E panel only

Symbol	P1	P2
1	770	725~770
2	770~800	725

Unit:mm



## FDT SERIES

## FDT100-140VH

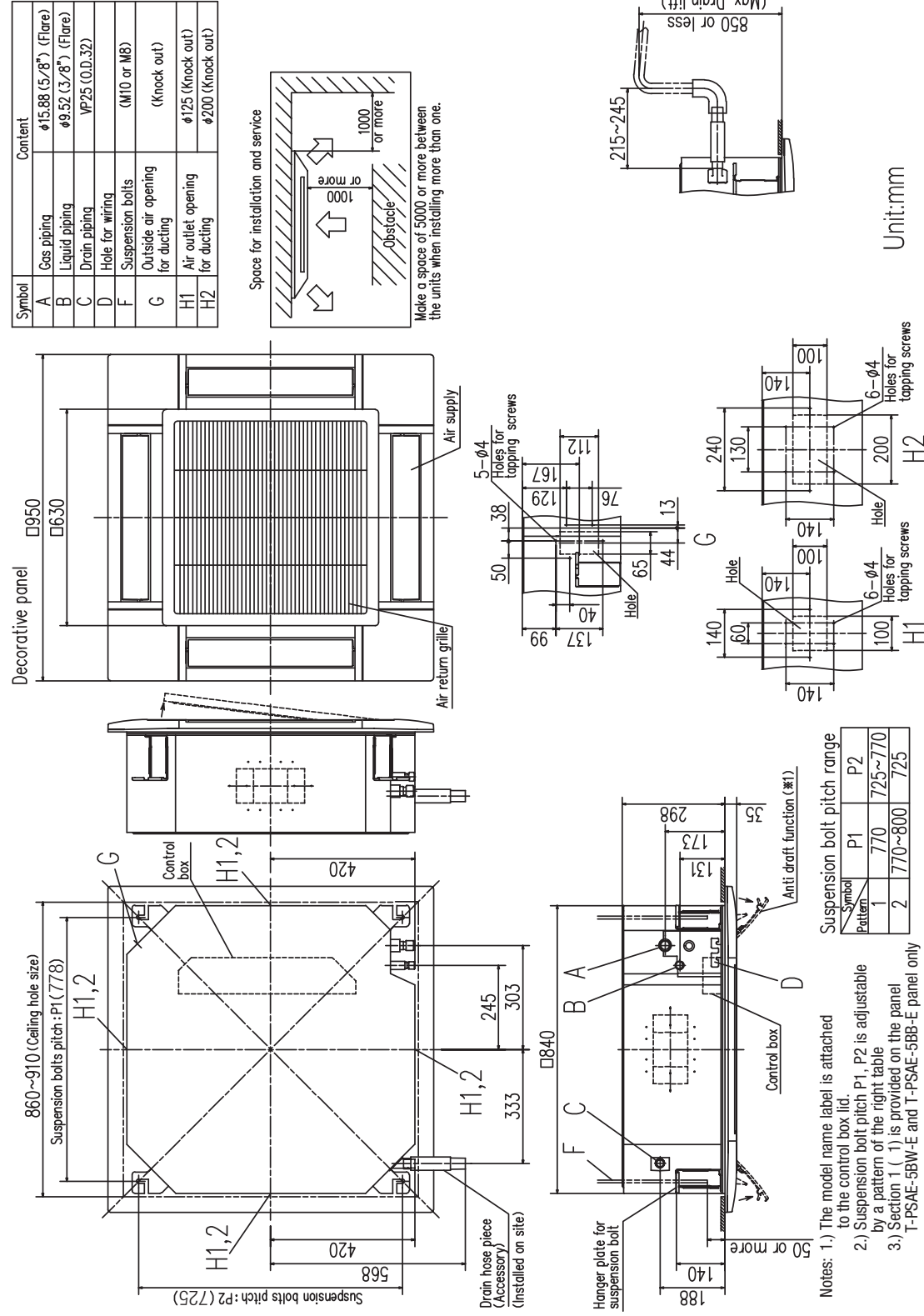

Symbol	Content
A	Gas piping φ15.88 (5/8") (Flare)
B	Liquid piping φ9.52 (3/8") (Flare)
C	Drain piping VP25 (O.D.32)
D	Hole for wiring
F	Suspension bolts (M10 or M8)
G	Outside air opening for ducting (Knock out)
H1	Air outlet opening for ducting φ125 (Knock out)
H2	Air outlet opening for ducting φ200 (Knock out)

Space for installation and service

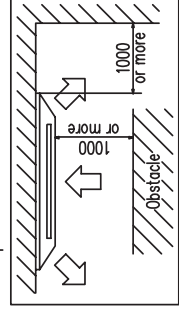

Make a space of 5000 or more between the units when installing more than one.

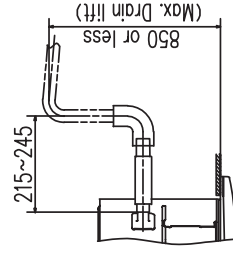

Unit:mm

## FDTC SERIES

## FDTC25-60VH

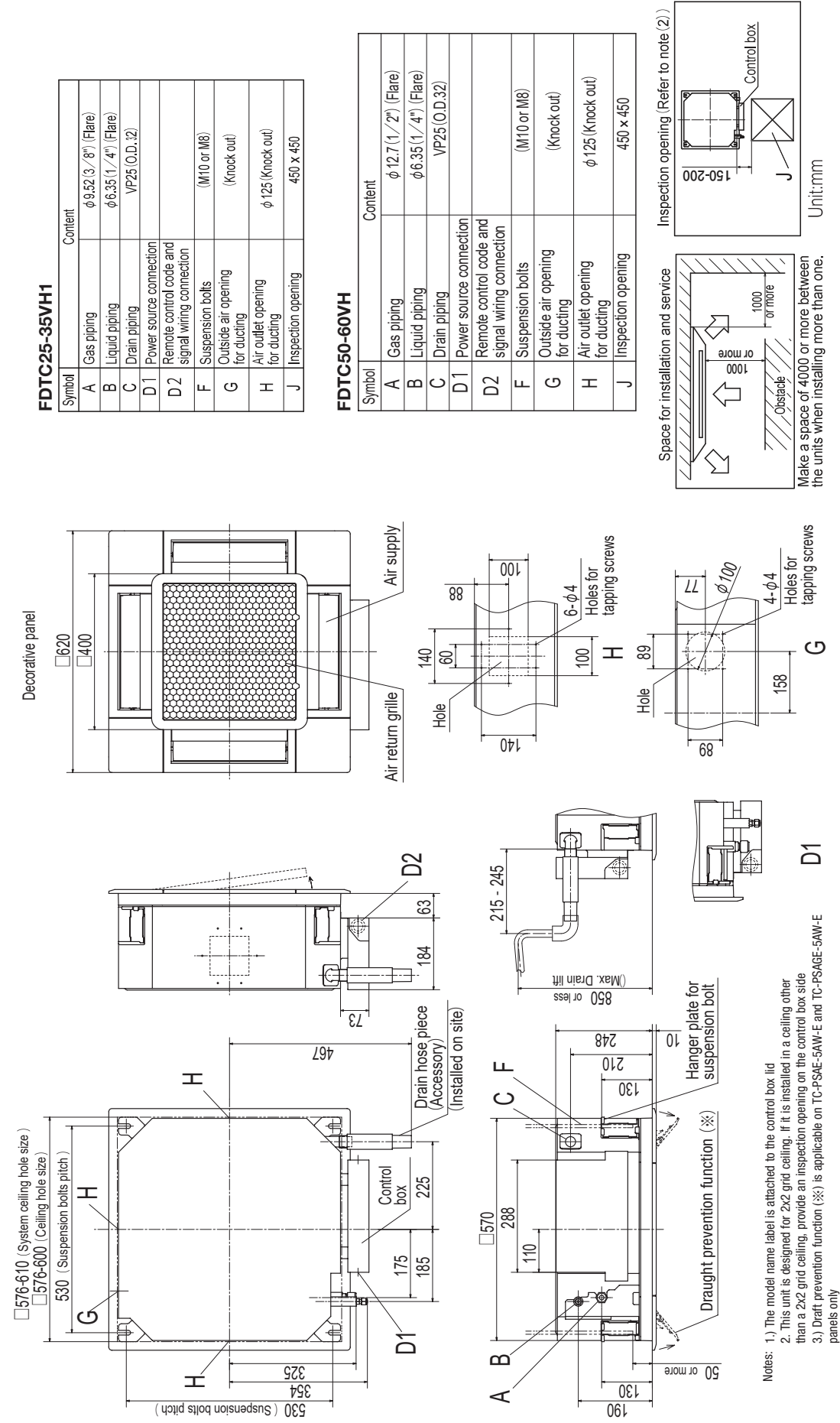

- Notes: 1.) The model name label is attached to the control box lid  
 2.) This unit is designed for 2x2 grid ceiling. If it is installed in a ceiling other than a 2x2 grid ceiling, provide an inspection opening on the control box side  
 3.) Draft prevention function (※) is applicable on TC-PSAE-5AW-E and TC-PSAGE-5AW-E panels only

EXTERIOR DIMENSIONS  
FDE SERIES

FDE71VH

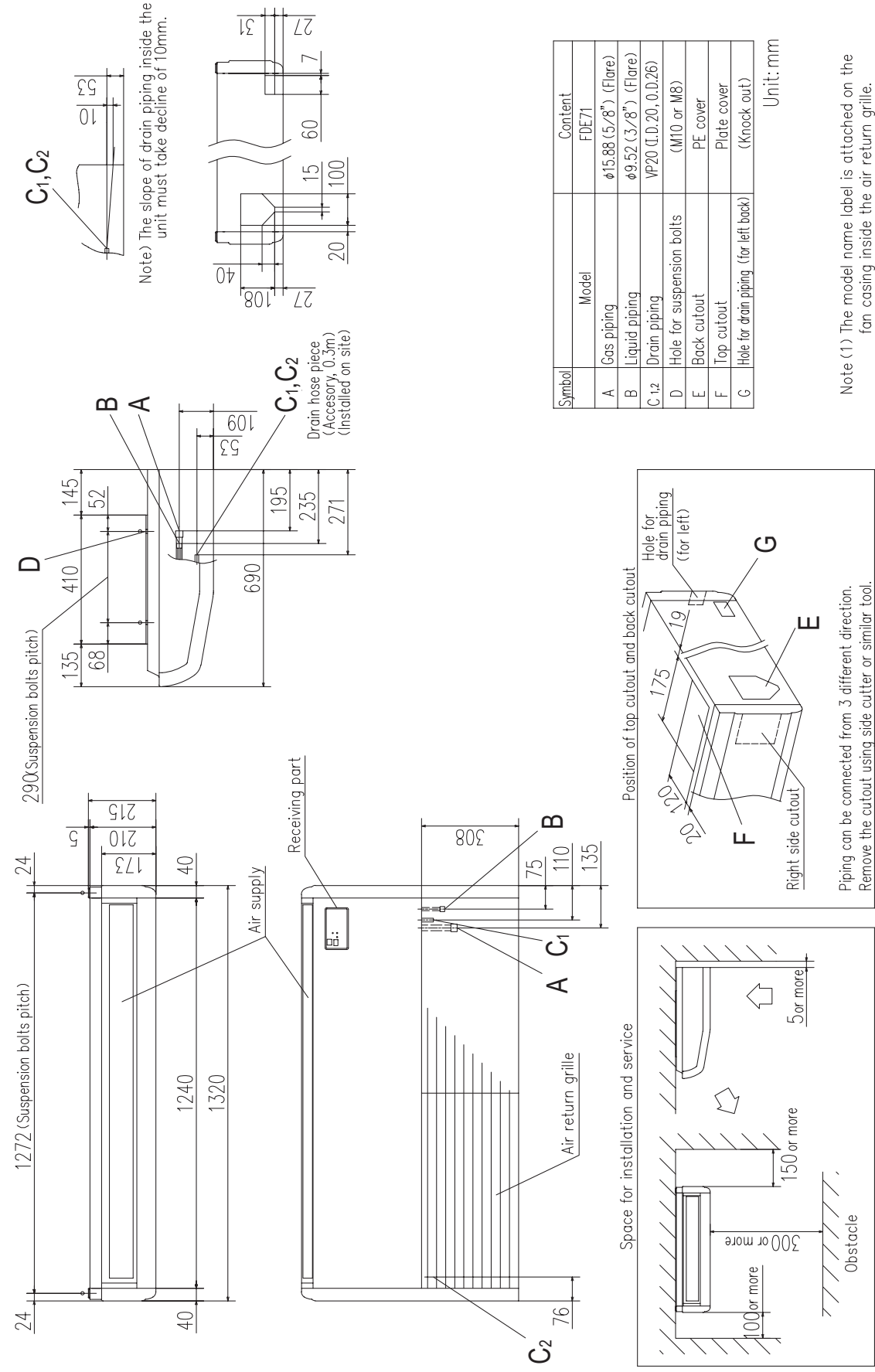

Note (1) The model name label is attached on the fan casing inside the air return grille.

EXTERIOR DIMENSIONS  
FDE SERIES

FDE100-140VH

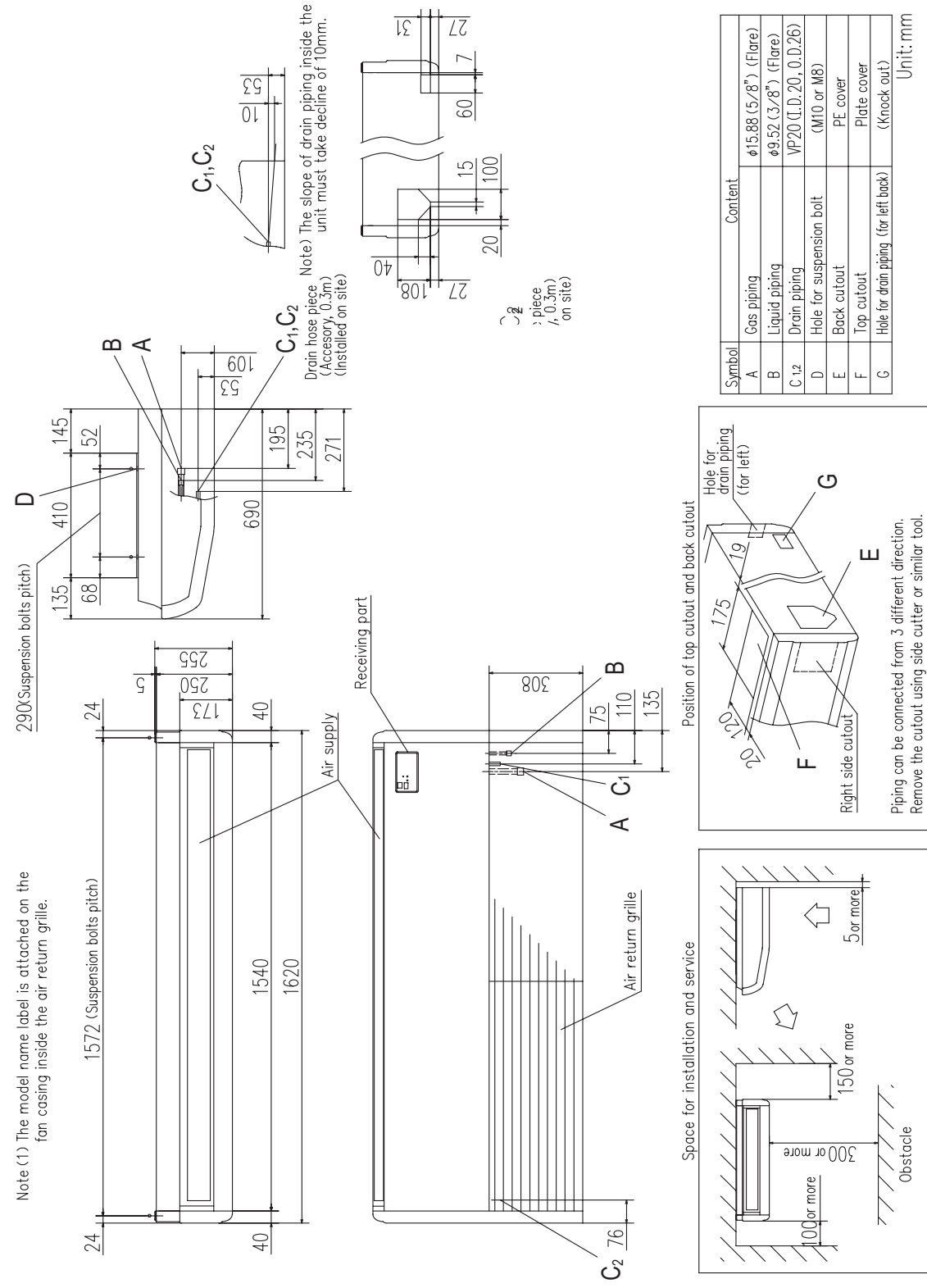

Note (1) The model name label is attached on the fan casing inside the air return grille.



# THE EXPERTS IN AIR

[mhiaa.com.au](http://mhiaa.com.au)

ABN 92 133 980 275

## **Australia:**

Phone: **1300 138 007**

### **NSW & Head Office**

Block E, 391 Park Road, Regents Park NSW 2143

### **Victoria**

2/15 Howleys Road, Notting Hill VIC 3168

### **Brisbane**

5/26 Flinders Parade, North Lakes QLD 4509

### **Adelaide**

T50 Innovation House, Mawsons Lakes Boulevard, Mawsons Lakes SA 5095

### **Townsville**

1/37 Ross River Road, Mysterton QLD 4812

### **Western Australia**

1/15-17 Capital Road, Malaga WA 6090

Mitsubishi Heavy Industries Air-conditioners Australia, Pty. Ltd.

MOVE THE WORLD FORWARD  MITSUBISHI  
HEAVY  
INDUSTRIES  
GROUP